

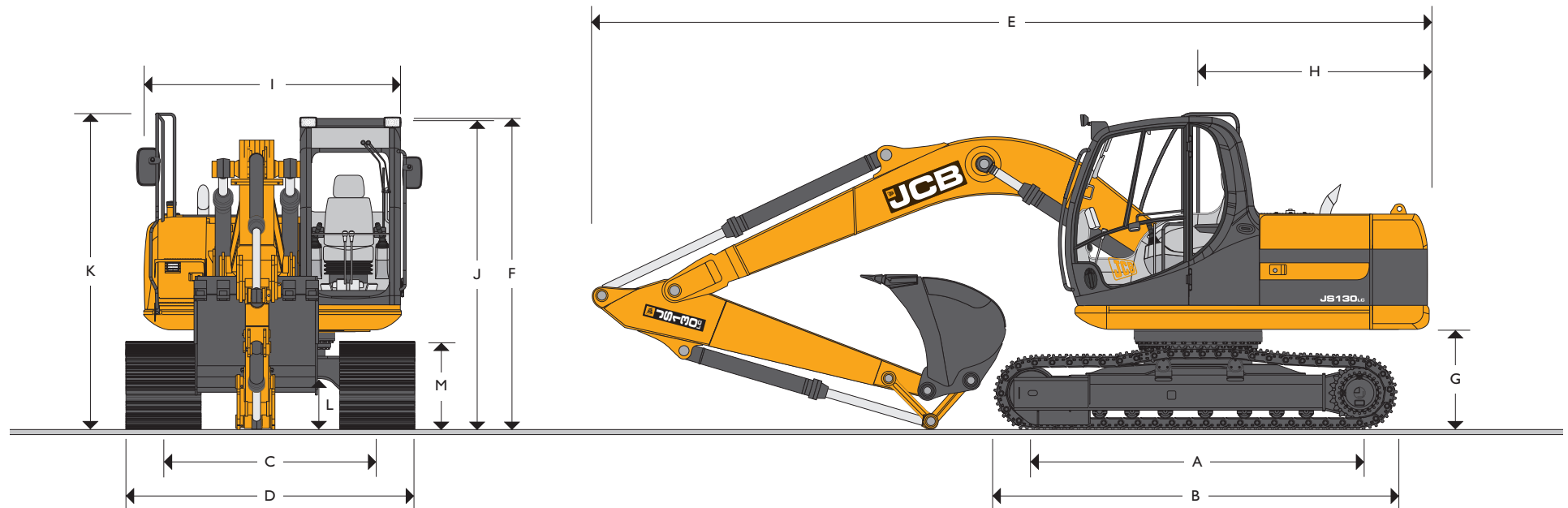

MAX. OPERATING WEIGHT: 13428 kg (29604 lb) MAX. ENGINE POWER: 73 kW (98 hp)



STATIC DIMENSIONS

Dimensions in millimetres (ft-in)		
A	Track length on ground	2865 (9-5)
B	Undercarriage overall length	3605 (11-10)
C	Track gauge	1990 (6-6)
D	Width over tracks (500mm trackshoes)	2490 (8-2)
D	Width over tracks (600mm trackshoes)	2590 (8-6)
D	Width over tracks (700mm trackshoes)	2690 (8-10)
Dipper lengths		
	2.5m (8ft 2in)	3.0m* (9ft 10in)
E	Transport length with Monoboam	7620 (25-0) 7572 (24-10)
F	*Transport height with Monoboam	2867 (9-5) 3289 (10-9)

Dimensions in millimetres (ft-in)		
G	*Counterweight clearance	905 (3-0)
H	Tail swing radius	2050 (6-9)
I	Width of superstructure	2410 (7-11)
J	*Height over cab	2845 (9-4)
K	*Height over grab rail	2867 (9-5)
L	*Ground clearance	425 (1-5)
M	Track height	811 (2-8)

*Machine in transport position



ENGINE

Model	Isuzu 4JJ1X Eu Stage IIIA, EPA Tier 3 compliant.
Type	Water cooled, 4-stroke, 4-cylinder in-line, common rail direct injection, turbocharged intercooled diesel.
Rated power (ISO 14899 (SAE J1995))	73kW (98hp) at 2000rpm.
Piston Displacement	2.999 litres (0.67 UK gal).
Injection	Electronic governor.
Air Filtration	Dry element with secondary safety element and in cab warning indicator.
Cooling	Large capacity radiator.
Starting system	24 volt – 4.5kW.
Batteries	2 x 12 volt.
Alternator	24 volt 50 amp.
Refuelling pump	Electric type.

SWING SYSTEM

Swing motor	Axial piston type.
Swing brake	Hydraulic braking plus automatic spring applied disc type parking brake.
Final drive	Planetary reduction.
Swing speed	12.8 rpm.
Swing gear	Large diameter, internally toothed fully sealed grease bath lubricated.
Swing lock	Multi position switchable brake.

UNDERCARRIAGE

Construction	Fully welded, "X" frame type with central bellyguarding and sloping sidemembers with dirt relief holes under top rollers.
Recovery point	Front and rear.
Upper & lower rollers	Heat treated, sealed and lubricated.
Track adjustment	Grease cylinder type.
Track type	Sealed and lubricated.
Track idler	Sealed and lubricated, with spring cushioned recoil.
Track shoes	500mm (20in.) triple grouser 600mm (24in.) triple grouser 700mm (28in.) triple grouser
Rollers and Shoes (each side)	Upper rollers 2 Lower rollers 7 Track shoes 44

HYDRAULIC SYSTEM

A variable flow load sensing system with flow on demand, variable power output and servo operated, multi-function open centre control. Machine auto warm up standard – maximises performance in cold conditions.

Pumps

Main pumps	2 variable displacement axial piston type.
Maximum flow	2 x 124 L/min (2 x 27 UK GPM).
Servo pump	Gear type.
Maximum flow	21 L/min (4.6 UK GPM).

Control valve

A combined four and five spool control valve with auxiliary service spool as standard. When required twin pump flow is combined to boom, dipper and bucket services for greater speed and efficiency.

Relief valve settings

Boom/Arm/Bucket	318 bar (4610lb/sq.in)
With power boost	343 bar (4975lb/sq.in)
Swing circuit	279 bar (4045lb/sq.in)
Travel circuit	343 bar (4975lb/sq.in)
Pilot control	40 bar (569lb/sq.in)

A separate Cushion Control valve in the servo system provides cushioning of the boom and dipper spools selection and quick warm-up of the servo system.

Hydraulic cylinders

Double acting type, with bolt-up end caps and hardened steel bearing bushes. End cushioning is fitted as standard on boom, dipper and bucket rams.

Optional hose burst check valves available for boom and dipper rams.

Filtration

The hydraulic components are protected by the highest standard of filtration to ensure long hydraulic fluid and component life.

In tank	150 micron, suction strainer.
Main return line	10 micron, fibreform element.
Plexus Bypass line	1.5 micron, paper element.
Pilot line	10 micron, paper element.
Hydraulic hammer return	10 micron, reinforced microform element.

Cooling

Worldwide cooling is provided as part of a single face cooling pack, in conjunction with the engine water cooler.

TRACK DRIVE

Type	Fully hydrostatic, three speed with autoshift between high and medium speed.
Travel motors	Variable swash axial piston type, fully guarded within undercarriage frame.
Final drive	Planetary reduction, bolt-on sprockets.
Service brake	Hydraulic counter balance valve to prevent overspeeding on gradients.
Park brake	Disc type, spring applied, automatic hydraulic release.
Gradeability	70% (35 deg) continuous.
Travel speed	High – 5.2 km/h (3.22 mph). Mid – 3.1 km/h (1.93 mph). Low – 2.6 km/h (1.62 mph).
Tractive effort	128kN (28800 lbf).



EXCAVATOR END

Monoboam available along with a choice of dipper lengths to suit the requirements of reach, dig-depth, loadover height, tearouts and site versatility. Reserve strength is built into the fully welded structures for hydraulic hammer and other arduous operations. Fabricated bucket tipping links are provided with a choice of lift points. Strong, durable construction, large cross sections and multi plate fabrications to withstand high stress applications. The 4.7m (15ft 5in) boom is designed to ensure the optimum digging envelope when matched with the three dipper lengths. Low maintenance bronze alloy bushes with graphite plugs are fitted to boom base and boom to dipper pivots resulting in 1000 hour greasing intervals at these points.

CAB

Excellent digging, loading and positioning visibility results from the careful design of front, side and roof lights. All screens are tinted to improve in cab conditions. Fully opening front screen is very smooth to operate and as the lower screen is stored within the top screen frame it makes complete front screen opening easy, fast and convenient. Fresh air ventilation available from opening door window, opening slot in front screen and fully opening front screen. Parallelogram wash wiper for upper screen ensuring good wiped area for maximum visibility. Wiper motor is fitted in the left hand side of the roof screen so as not to affect bucket visibility when loading. Optional lower screen wiper available. Fresh air ventilation and heater with windscreen demister. Infinitely variable blower speed, temperature and recirculation control with optional climate control. Fully adjustable deluxe suspension seat with arm rest adjustment and backrest recline. Optional radio with digital tuner fitted into the roof lining for maximum protection. Conveniently placed radio mute button incorporated into lower console. 12v power point and mobile phone holder built into the right hand console. Courtesy light can be operated from ground level and is illuminated for five minutes or until switched off improving operator access at night. Cab mounted roller blind protects operator from suns' glare through front or top screens.

AMS – ADVANCED MANAGEMENT SYSTEM

Four selectable working modes link the operators control movements with the engine and hydraulic systems to maximise productivity and efficiency.

- A (Auto)** Up to 100% engine power and 100% flow. Gives variable power and speed depending on the operator's input, matching the demand for output and efficiency to the job. Power boost is automatically activated in this mode should hard conditions be encountered. Auto idle cuts in after a period of inactivity (between 5 and 30 seconds as set by the operator)
- E (Economy)** 80% engine power. 95% of hydraulic flow maximises economy while maintaining excellent output.
- P (Precision)** 55% engine power. 90% of hydraulic flow for fine control of grading operations.
- L (Lifting)** 55% engine power. 63% of hydraulic flow with permanent power boost for maximum lifting power and control.

The Auto mode allows the AMS processor to select the optimum operational performance to match the demands of the job while the three alternative modes give precise matching of application when specific tasks are undertaken.

The adjustable position monitor mounted on the front right hand pillar of the cab gives the operator a constant read out of mode, tracking range, operating temperature and a host of other information, while retaining excellent visibility of the monitor and the job being carried out.

The required flow for hammer applications can be set and stored in the AMS memory and is automatically activated whenever the hammer pedal is depressed.

A maintenance indicator warns of imminent service needs, and all servicing and basic checks can be carried out using only the in cab display.

CONTROLS

- Excavator** All servo lever operated to ISO control pattern, independently adjustable to the seat.
- Tracks** Individually servo operated by foot pedal or hand lever. Speed selection via joystick button. Via servo operated foot pedal.
- Auxiliary** Via servo operated foot pedal.
- Control isolation** Via gate lock lever at cab entrance or panel switch.
- Engine speed** Dial type throttle control plus servo lever mounted one-touch idle control or separate selectable auto-idle with adjustable time delay using AMS.
- Engine stop** Ignition key operated and separate shut-down button.
- Horn** Operated via servo lever mounted button.
- Optional blade control** Independent lever in cab.

SERVICE CAPACITIES

	Litres	UK Gal
Fuel tank	253	55.6
Engine coolant	16.4	3.6
Engine oil	15	3.3
Swing reduction gear	2.2	0.5
Track reduction gear (each side)	3.5	0.7
Hydraulic system	124.0	27.3
Hydraulic tank	73.0	16.1

WEIGHTS AND GROUND BEARING PRESSURES

Machine equipped with 4.7m Monoboom, 2.5m Dipper, Standard Excavating Bucket, operator and full fuel tank.

Shoe Width	Operating Weight	Bearing Pressure
500mm (20in.)	12766kg (28144lb)	0.41kg/sq. cm. (5.83lb/sq. in.)
600mm (24in.)	12956kg (28563lb)	0.35kg/sq. cm. (4.98lb/sq. in.)
700mm (28in.)	13147kg (28984lb)	0.30kg/sq. cm. (4.27lb/sq. in.)

STANDARD / OPTIONAL EQUIPMENT

Standard Equipment: Engine fan guard; Cold start pre-heat; Auto engine warm up; Double element air cleaner; Heavy-duty alternator; Electrics isolator; Heavy-duty batteries; Cab & engine soundproofing; Cab heater & screen demister; Tinted glass; Interior light; Coat hook; Cigarette lighter; Ashtray; Operator's storage shelf with cargo net; Removable floor mat; Windscreen wash/wipe; Plug-in power socket; Automatic power boost; Auto-idle; One-touch engine speed control; Hydraulic cushion control; Plexus hydraulic oil filtration; HSP pressure test points; Auxiliary pipework mounting brackets; Work lights – boom & mainframe mounted; Undercarriage belly guarding; Upper structure under covers; Swing system cover; External mirrors; Handrail & non slip walk ways; Quick connect engine oil drain pipe; Front screen blind; Quick connect fuel tank drain pipe; Hinged engine under cover.

Optional Equipment: Hose burst check valves & overload warning system; Tipping link mounted lift points; General purpose buckets; Ditch/grading buckets; Quickhitch buckets; Hydraulic hammers; Auxiliary pipework (full and low flow); Climate control; Cab mounted & rear work lights; Rotating beacon; Rain guard; Biodegradable oil; Radio & cassette player; Air suspension seat with heated pad and lumbar support adjustment; Electric refuelling pump; Single track guide; Lower screen wiper; Radio; Hot and cold climate hydraulic oil; Engine air intake precleaners; Leveling; Stabilising blade; Various track plate widths, additional cab mounted work lights, FOPS guard cab protection, seat belt, cab mesh screen guard, fire extinguisher, cab vandal cover kit, travel alarm.

BUCKET AND ARM COMBINATION

JCB Bucket	No Q/Hitch Fitted		Q/Hitch Fitted	
	2.5m (8ft 2in)	3.0m (9ft 10in)	2.5m (8ft 2in)	3.0m (9ft 10in)
GP 500mm wide 0.235 cu.m (SAE heaped)	□	□	□	□
GP 600mm wide 0.315 cu.m (SAE heaped)	□	□	□	□
GP 700mm wide 0.39 cu.m (SAE heaped)	□	□	□	■
GP 750mm wide 0.43 cu.m (SAE heaped)	□	□	■	●
GP 800mm wide 0.47 cu.m (SAE heaped)	□	■	■	●
GP 900mm wide 0.55 cu.m (SAE heaped)	□	■	●	×
GP 1000mm wide 0.63 cu.m (SAE heaped)	□	●	●	×
GP 1100mm wide 0.715 cu.m (SAE heaped)	■	×	×	×
GP 1200mm wide 0.795 cu.m (SAE heaped)	■	×	×	×
GP 1300mm wide 0.88 cu.m (SAE heaped)	×	×	×	×

- = Suitable for General Excavating (Materials up to 2000kg/cu.m.)
 - = Suitable for Light Excavating (Materials up to 1600kg/cu.m.)
 - = Suitable for Grading & Loading Materials up to 1200kg/cu.m.
 - ×
- × = Not Warranted

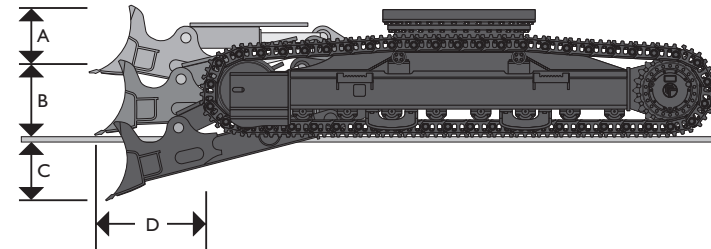
OPTIONAL BLADE

A Blade height	mm (ft-in)	490 (1-7)
B Blade lift above ground	mm (ft-in)	405 (1-4)
C Blade cut below ground	mm (ft-in)	545 (1-9)
D Blade forward of track	mm (ft-in)	425 (1-5)
Dozer width – 500mm tracks	mm (ft-in)	2510 (8-3)
Dozer width – 600mm tracks	mm (ft-in)	2610 (8-7)
Dozer width – 700mm tracks	mm (ft-in)	2710 (8-11)
Additional machine weight with blade		
500mm tracks	kg (lb)	747 (1647)
600mm tracks	kg (lb)	753 (1660)
700mm tracks	kg (lb)	759 (1673)





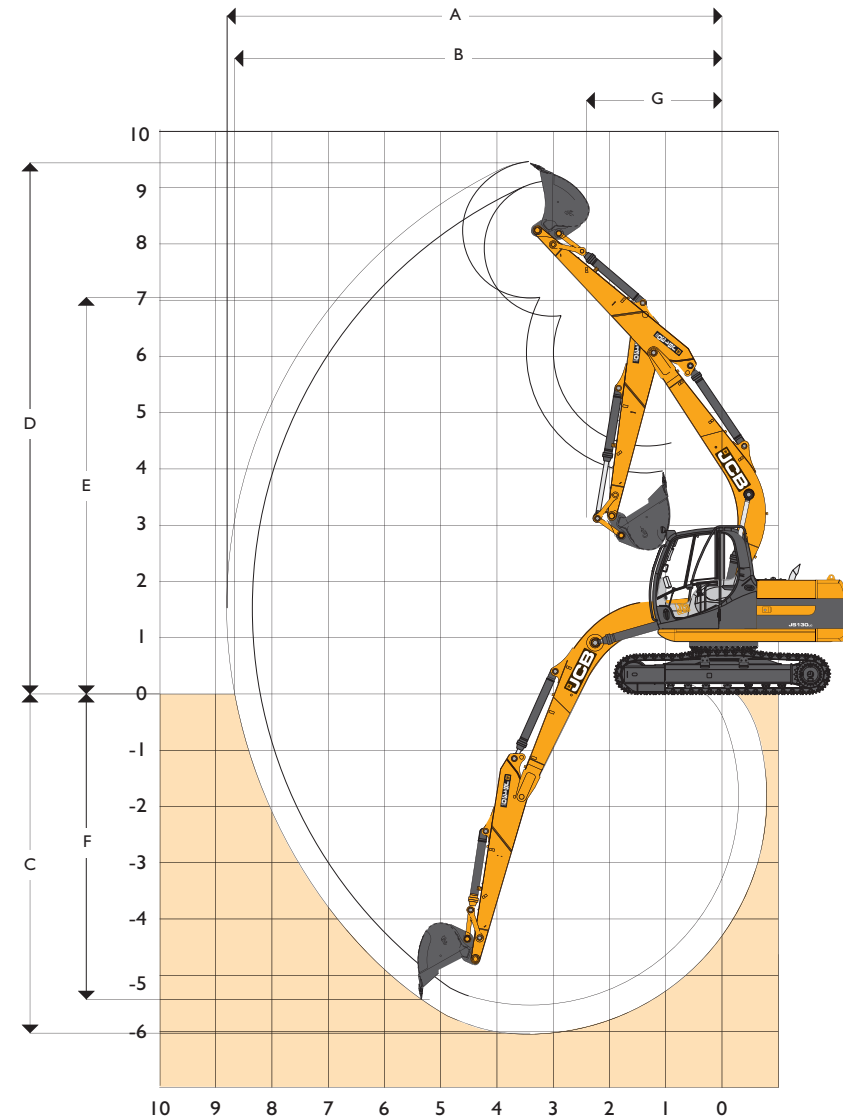







WORKING RANGE

Boom length: 4.70m (15ft 5in)		
Dipper length:		2.50m (8ft 2in)
A	Maximum digging reach	mm (ft-in) 8340 (27-4)
B	Maximum digging reach (on ground)	mm (ft-in) 8197 (26-11)
C	Maximum digging depth	mm (ft-in) 5530 (18-2)
D	Maximum digging height	mm (ft-in) 9118 (29-11)
E	Maximum dumping height	mm (ft-in) 6729 (22-1)
F	Maximum vertical wall cut depth	mm (ft-in) 3625 (11-11)
G	Minimum swing radius	mm (ft-in) 2231 (7-4)
	Bucket rotation	182°
	Maximum dipper tearout (ISO 6015)	kgf (lbf) 6680 (14720)
	Maximum bucket tearout (ISO 6015)	kgf (lbf) 9375 (20667)
Dipper length: 3.00m (9ft 10in)		
A	Maximum digging reach	mm (ft-in) 8796 (28-10)
B	Maximum digging reach (on ground)	mm (ft-in) 8660 (28-5)
C	Maximum digging depth	mm (ft-in) 6028 (19-9)
D	Maximum digging height	mm (ft-in) 9440 (30-11)
E	Maximum dumping height	mm (ft-in) 7041 (23-1)
F	Maximum vertical wall cut depth	mm (ft-in) 4050 (13-3)
G	Minimum swing radius	mm (ft-in) 2591 (8-6)
	Bucket rotation	182°
	Maximum dipper tearout (ISO 5016)	kgf (lbf) 5970 (13161)
	Maximum bucket tearout (ISO 5016)	kgf (lbf) 9375 (20667)















LIFT CAPACITIES – Dipper Length: 2.50m, 4.70m Monoboom, Trackshoes: 700mm, No bucket.

JS130 LC MONO

Reach	1.5m (4ft 11in)		3m (9ft 10in)		4.5m (14ft 9in)		6m (19ft 8in)		7.5m (24ft 7in)		Capacity at Max Reach		
													mm
Load Point Ht.	kg	kg	kg	kg	kg	kg	kg	kg	kg	kg	kg	kg	mm
7.5m (24.7ft)												2960*	3828
6.0m (19.8ft)					2900*	2900*						2380*	5539
4.5m (14.9ft)					3150*	3150*	3080	2120				2200*	6483
3.0m (9.10ft)			5410*	5410*	3920*	3190	3000	2050				2180*	6984
1.5m (4.11ft)			7460*	5330	4490	2960	2900	1950				2220	7136
0m			6840*	5060	4310	2800	2810	1870				2270	6965
- 1.5m (- 4.11ft)	5120*	5120*	8460	5030	4240	2740	2780	1840				2520	6442
- 3.0m (- 9.10ft)	9300*	9300*	7440*	5130	4280	2780						3230	5467
- 4.5m (- 14.9ft)													

LIFT CAPACITIES – Dipper Length: 3.00m, 4.70m Monoboom, Trackshoes: 700mm, No bucket.

JS130 LC MONO

Reach	1.5m (4ft 11in)		3m (9ft 10in)		4.5m (14ft 9in)		6m (19ft 8in)		7.5m (24ft 7in)		Capacity at Max Reach		
													mm
Load Point Ht.	kg	kg	kg	kg	kg	kg	kg	kg	kg	kg	kg	kg	mm
7.5m (24.7ft)					2850*	2850*						2570*	4632
6.0m (19.8ft)					2410*	2410*	2530*	2150				2180*	6118
4.5m (14.9ft)					2710*	2710*	2760*	2150				2050*	6983
3.0m (9.10ft)			4470*	4470*	3490*	3240	3020	2060				2040*	7450
1.5m (4.11ft)			7000*	5450	4470	2980	2890	1940	2040	1370		2000	7593
0m			7510*	5030	4290	2780	2790	1850				2030	7432
- 1.5m (- 4.11ft)	4590*	4590*	8420	4930	4190	2680	2730	1790				2230	6945
- 3.0m (- 9.10ft)	7890*	7890*	7860*	4990	4190	2690	2760	1820				2730	6054
- 4.5m (- 14.9ft)			5970*	5200	3710*	2840						3680*	4517



Lift capacity front and rear.



Lift capacity full circle.

- Notes:**
1. The above loads are in compliance with SAE and ISO Hydraulic Excavator Lift Capacity Standards.
 2. They do not exceed 87% of hydraulic lifting capacity or 75% of tipping load.
 3. Rated loads marked with an asterisk (*) are limited by hydraulic capacity rather than tipping load.

LIFT CAPACITIES – Dipper Length: 2.50m, 4.70m Monoboom, Trackshoes: 700mm, No bucket, Dozer.
JS130 LC MONO

Reach	1.5m (4ft 11in)		3m (9ft 10in)		4.5m (14ft 9in)		6m (19ft 8in)		7.5m (24ft 7in)		Capacity at Max Reach			
													mm	
Load Point Ht.	kg	kg	kg	kg	kg	kg	kg	kg	kg	kg	kg	kg	mm	
7.5m (24.7ft)												2960*	2960*	3828
6.0m (19.8ft)					2900*	2900*						2380*	2380*	5539
4.5m (14.9ft)					3150*	3150*	3110*	2240				2200*	1950	6483
3.0m (9.10ft)			5410*	5410*	3920*	3370	3280	2170				2180*	1690	6984
1.5m (4.11ft)			7460*	5650	4840*	3140	3170	2080				2300*	1600	7136
0m			6840*	5380	4720	2980	3090	2000				2490	1620	6965
- 1.5m (- 4.11ft)	5120*	5120*	8460*	5350	4650	2920	3060	1970				2780	1800	6442
- 3.0m (- 9.10ft)	9300*	9300*	7440*	5450	4690	2960						3540	2290	5467
- 4.5m (- 14.9ft)														

LIFT CAPACITIES – Dipper Length: 3.00m, 4.70m Monoboom, Trackshoes: 700mm, No bucket, Dozer.
JS130 LC MONO

Reach	1.5m (4ft 11in)		3m (9ft 10in)		4.5m (14ft 9in)		6m (19ft 8in)		7.5m (24ft 7in)		Capacity at Max Reach			
													mm	
Load Point Ht.	kg	kg	kg	kg	kg	kg	kg	kg	kg	kg	kg	kg	mm	
7.5m (24.7ft)					2850*	2850*						2570*	2570*	4632
6.0m (19.8ft)					2410*	2410*	2530*	2270				2180*	2180*	6118
4.5m (14.9ft)					2710*	2710*	2760*	2270				2050*	1730	6983
3.0m (9.10ft)			4470*	4470*	3490*	3420	3080*	2180				2040*	1520	7450
1.5m (4.11ft)			7000*	5770	4470*	3160	3170	2070	2250	1460		2130*	1430	7593
0m			7510*	5360	4700	2960	3060	1970				2240	1450	7432
- 1.5m (- 4.11ft)	4590*	4590*	8550*	5250	4590	2860	3010	1920				2450	1580	6945
- 3.0m (- 9.10ft)	7890*	7890*	7860*	5310	4600	2870	3040	1950				3000	1930	6054
- 4.5m (- 14.9ft)			5970*	5520	3710*	3020						3680*	3010	4517



Lift capacity front and rear.



Lift capacity full circle.

- Notes:**
1. The above loads are in compliance with SAE and ISO Hydraulic Excavator Lift Capacity Standards.
 2. They do not exceed 87% of hydraulic lifting capacity or 75% of tipping load.
 3. Rated loads marked with an asterisk (*) are limited by hydraulic capacity rather than tipping load.

A GLOBAL COMMITMENT TO QUALITY

JCB's total commitment to its products and customers has helped it grow from a one-man business into Britain's largest privately owned manufacturer of backhoe loaders, crawler excavators, wheeled excavators, telescopic handlers, wheeled loaders, dump trucks, rough terrain fork lifts, industrial fork lifts, mini/midi excavators, skid steer loaders, tractors and compaction equipment.

By making constant and massive investments in the latest production technology, the JCB factories have become some of the most advanced in the world.

By leading the field in innovative research and design, extensive testing and stringent quality control, JCB machines have become renowned all over the world for performance, value and reliability.

And with a global sales and service network of more than 650 dealers and agents, we aim to deliver the best customer support in the industry.

Through setting the standards by which others are judged, JCB has become one of the world's most impressive success stories.

